



Georgia State Amendments to the CABO One and Two Family Dwelling Code

(2000 Edition)



**Georgia Department of Community Affairs
Office of Coordinated Planning
60 Executive Park South, N.E.
Atlanta, Georgia 30329-2231
(404) 679-3118
www.dca.state.ga.us**

Revised January 1, 2002

ONE AND TWO FAMILY DWELLING CODE
(International Residential Code for
One and Two Family Dwellings)

The CABO ONE AND TWO FAMILY DWELLING CODE (International Residential Code for One and Two Family Dwellings), 2000 Edition, published by the Southern Building Code Congress International, Inc., when used in conjunction with these Georgia Amendments, shall constitute the official *Georgia State Minimum Standard One and Two Family Dwelling Code*.

Plumbing (Chapters 25 through 32) are deleted from the *CABO One and Two Family Dwelling Code* in accordance with Title 8, Chapter 2, Article 1, Part 2 of the Official Code of Georgia Annotated.

Electrical (Chapters 33 through 42) are deleted and substitute for Electrical requirements the *Georgia State Minimum Standard Electrical Code (National Electrical Code 1999 Edition)*.

Appendices

Appendices are not enforceable unless they are specifically referenced in the body of the code or adopted for enforcement in the ordinance of the authority having jurisdiction.

GEORGIA STATE AMENDMENTS

CODE REFERENCE:

- (a) Change all references from the ICC Electrical Code to the Georgia State Minimum Standard National Electrical Code.
- (b) Change all references from the International Energy Conservation Code to the Georgia State Energy Code for Buildings. The Georgia State Energy Code for Buildings shall be used for efficiency and coefficient of ratings for heating and air conditioning equipment.

Scope

The provisions of the CABO One and Two Family Dwelling Code (International Residential Code for One and Two Family Dwellings) shall apply to the construction, alteration, movement, enlargement, replacement, repair, equipment, use and occupancy, location, removal and demolition of detached one- and two-family dwellings and multiple single family dwellings (townhouses) not more than three stories in height with a separate means of egress and their accessory structures.

**GEORGIA STATE MINIMUM
REQUIREMENTS FOR BOILER/WATER HEATERS AND PRESSURE VESSELS**

(a). The State's Minimum requirements for Boiler/Water Heaters and Pressure Vessels, over 200,000 BTU (58.56kW), 210 degrees Fahrenheit, or 120 gallons capacity, shall be established by O.C.G.A. Title 34, Chapter 11, and the Rules and Regulations of the Georgia Department of Labor. (Effective January 1, 2002)

**Revise the CABO One and Two Family Dwelling Code (International Residential Code for One and Two Family Dwellings), 2000 Edition, as follows:*

**CHAPTER 1
ADMINISTRATION**

* Delete Chapter 1 without substitution. Chapter 1 to remain in the Code as a *reference and guide* for local governments in development of their own *Administrative Procedures*. (Effective January 1, 2002)

**CHAPTER 2
DEFINITIONS**

*Revise Section R202 by adding the following definitions:

ABSORPTION SYSTEM. A refrigerating system in which refrigerant is pressurized by pumping a chemical solution of refrigerant in absorbent, and then separated by the addition of heat in a generator, condensed (to reject heat), expanded, evaporated (to provide refrigeration), and reabsorbed in an absorber to repeat the cycle; the system may be single or multiple effect, the latter using multiple stages or intentionally cascaded use of heat to improve efficiency. (Effective January 1, 2002)

BASEMENT. A basement shall not be considered as a story if the finished surface of the floor above the basement is:

- Less than 6 feet (1829 mm) above grade plane; or
 - Less than 6 feet (1829 mm) above the finished ground level for more than 50 percent of the building perimeter; and
 - Is less than 12 feet (3658 mm) above finished ground level around the entire building perimeter.
- (Effective January 1, 2002)

EXTERIOR INSULATION AND FINISH SYSTEMS (EIFS). Exterior Insulation and Finish Systems are non-load bearing exterior wall cladding systems generally consisting of an insulation board, an adhesive and/or mechanical attachment of the insulation board to the substrate, glass fiber reinforcing mesh, a base coat on the face of the insulation board and an aggregated polymer binder based finish coat. (Effective January 1, 2002)

Story Above Grade. Any story having its finished floor surface entirely above grade except that a basement shall be considered as a story above grade when the finished surface of the floor above the basement is:

- More than 6 feet (1829 mm) above grade plane;
- More than 6 feet (1829 mm) above the finished ground level for more than 50 percent of the total building perimeter; or
- More than 12 feet (3658 mm) above the finished ground level at any point.
(Effective January 1, 2002)

Ventilating Area, Net Free (NFVA). The Net Free Ventilating Area (NFVA) of a static ventilating device is the sum of the smallest cross-sectional areas of airways in the device.
(Effective January 1, 2002)

CHAPTER 3 BUILDING PLANNING

SECTION R303 LIGHTING, VENTILATION AND HEATING

*Add exception to Section R303.4 and renumber existing and new exceptions as 1 & 2 respectively.

Section R303.4 Stairway illumination.

Exceptions:

1. An artificial light source is not required at the top and bottom landing, provided an artificial light source is located directly over each stairway section.
2. All stairways which are not required by Section 310 as part of an emergency exit will not be required to be illuminated by artificial light.
(Effective January 1, 2002)

SECTION R309 GARAGES AND CARPORTS

*Add exception to Section R309.2 to read as follows:

Section R309.2 Separation required.

Exception:

In garages protected by an automatic sprinkler system installed in accordance with NFPA 13D, a separation is not required.
(Effective January 1, 2002)

SECTION R314 STAIRWAYS

*Revise Section R314.2 to read as follows and add exception:

R314.2 Treads and risers. The maximum riser height shall be 7 ¾ inches (196 mm) and the minimum tread depth shall be 9 inches (229 mm). (Remainder of section left unchanged)

Exception.

The first and the last riser may vary by an amount no greater than ¾ inch (19 mm) from the other risers in the flight of stairs.

(Effective January 1, 2002)

* Delete Section R314.2.1 and substitute the following:

R314.2.1 Profile. The radius of curvature, if any, at the leading edge of the tread shall be no greater than 9/16 inch (14.3 mm). A nosing projection of not less than ¾ inch (19 mm) but not more than 1 ½ inches (38 mm) shall be provided on treads with solid risers. Beveling of nosing shall not exceed ½ inch (12.7 mm). Risers shall be vertical or sloped from the underside of the leading edge of the tread above at an angle not more than 30 degrees from the vertical.

Exception. A nosing is not required where the tread depth is a minimum of 11 inches (279 mm). (Effective January 1, 2002)

SECTION R315 HANDRAILS

* Delete Section R315.1 and substitute the following:

R315.1 Handrails. Handrails having minimum and maximum heights of 30 inches and 38 inches (762 mm and 965 mm), respectively, measured vertically from the nosing of the treads, shall be provided on at least one side of stairways of 30 inches (762 mm) or more in height. Spiral stairways and winders shall have the required handrail located on the outside radius. All required handrails shall be continuous the full length of the stairs excluding the landings. Ends shall be returned or shall terminate in newel posts or safety terminals. Handrails projecting from a wall shall have a space not less than 1½ inches (38 mm) between the wall and the handrail.

Exception:

1. Handrails shall be permitted to be interrupted by a newel post at a turn.
2. The use of a volute, turnout or starting easing shall be allowed over the lowest tread.
3. Handrails may be interrupted within the width of a tread where the wall configuration changes.

(Effective January 1, 2002)

* Delete Section R315.2 and substitute the following:

R315.2 Handrail grip size. Handrails shall have either a circular cross section with a diameter of 1 ¼ (32 mm) to 2 inches (51 mm), or a noncircular cross section with a perimeter dimension of at least 4 inches (102 mm) but not more than 6 ¼ inches (159 mm) and a largest cross section dimension not exceeding 2 ¾ inches (69.9 mm). Edges shall have a minimum radius of 1/8 inch (3.2 mm).

(Effective January 1, 2002)

SECTION R317 SMOKE ALARMS

The State's minimum requirements for smoke detection systems shall be established by the Life Safety Code. Areas not specifically addressed by the Life Safety Code and which are addressed by the Georgia State Minimum Standard Building Code, the Georgia State Minimum Standard One and Two Family Dwelling Code or the Georgia State Minimum Standard Fire Prevention Code shall be used as a supplement.

Exception: State's minimum requirements for smoke detectors in One and Two Family Dwellings shall be established by O.C.G.A. Title 25, Chapter 2.

*Delete Section R317.1 and substitute the following:

R317.1 Smoke detectors required. Smoke detectors shall be installed outside of each sleeping area in the immediate vicinity of the bedrooms, but in no case more than 10 feet away from the door, and on each additional story of the dwelling, including basements and cellars but not including crawlspaces and uninhabitable attics. In dwellings with split levels, a smoke detector needs to be installed only in the upper level, provided the lower level is less than one full story below the upper level, except that if there is a door between levels, then a smoke detector is required on each level. All detectors shall be interconnected such that the actuation of one will actuate all the alarms in the individual unit and shall provide an alarm which is audible in all sleeping areas. All detectors shall be approved and listed and installed in accordance with the manufacturer's instructions.

(Effective January 1, 2002)

SECTION R321 DWELLING UNIT SEPARATION

*Revise Section R321.1 by adding an exception and numbering exceptions as 1 & 2 to read as follows:

R321.1 Two-family dwellings.

#2. Two family dwellings that qualify for independent electrical (separate) services shall be separated with a minimum two- hour fire rated assembly.

(Effective January 1, 2002)

**SECTION R322
MOISTURE VAPOR RETARDERS**

*Delete Section R322.1 and substitute the following:

R322.1 Retarder required. In all frame walls, and floors, and ceilings, not ventilated to allow moisture to escape, an approved vapor retarder having a maximum perm rating of 1.0, when tested in accordance with Procedure for Desiccant of Method ASTM E 96 shall be used on the warm-in-winter side of the thermal insulation. The moisture vapor retarders shall also comply with the Georgia State Energy Code for Buildings.

Exceptions: In construction where moisture or its freezing will not damage the materials.
(Effective January 1, 2002)

**SECTION R324
PROTECTION AGAINST TERMITES**

* Revise Section R324.1 by adding a sentence at the end of section to read as follows:

R324.1 Subterranean termite control. ...any combination of these methods. Clearance between exterior wall cladding, except masonry veneer, shall be at least 6 inches (152 mm) and a 2 inch (51 mm) clear inspections space above paved areas must be visible below cladding down to the final grade of the top of the soil which is immediately adjacent to the structure.
(Effective January 1, 2002)

*Add new Section R324.5 to read follows:

R324.5 Removal of debris: Cells and cavities in masonry units of foundation and basement walls shall be cleaned of all trash, debris, wood scraps, and other extraneous content before concrete placement.
(Effective January 1, 2002)

**CHAPTER 4
FOUNDATIONS**

**SECTION 403
FOOTINGS**

*Revise Figure R403.1(1) Concrete and Masonry Foundation Details

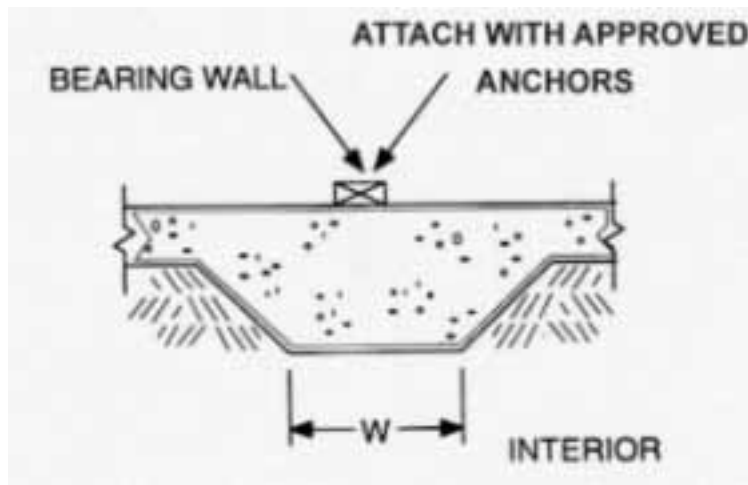

(Effective January 1, 2002)

**SECTION R404
FOUNDATION WALLS**

*Add exception to Section R404.1.7 to read as follows and number exceptions as 1 and 2:

R404.1.7 Backfill placement.

Exception:

1. Such bracing is not required for walls supporting less than 4 feet (1219 mm) of unbalanced backfill.
2. Such bracing is not required for poured concrete walls having sufficient strength.

(Effective January 1, 2002)

**CHAPTER 5
FLOORS**

**SECTION R502
WOOD FLOOR FRAMING**

*Revise Section R502.2.1 to read as follows:

R502.2.1 Decks. Decks shall be constructed in accordance with this code or Chapter 3 of the 1996 Forest Products Society, “Wood Decks, Materials, Construction, and Finishing” manual. (Remainder of section left unchanged.)
(Effective January 1, 2002)

*Add new Sections R502.2.1.1, R502.2.1.2, R502.2.1.3, R502.2.1.4 and R502.2.1.5 to read as follows:

R502.2.1.1 Guardrails. Guardrails shall comply with the live load requirements in Section R301.4. Guardrails may be constructed as per Figures 44 and 45 of the 1996 Forest Products Society, “Wood Decks, Materials, Construction, and Finishing” manual, and meet the design criteria as described in Section R316.

Exception: Stairway Guardrails shall meet live load requirements specified in Section R301.4.

R502.2.1.2 Footings. Footing design for decks and porches shall be as required in Section R403.

R502.2.1.3 Stairways. Stairways shall comply with Section R314.

R502.2.1.4 Protection against decay. Protection against decay shall be in accordance with Section R323.

R502.2.1.5 Protection against termites. Protection against termites shall be in accordance with Section R324.
(Effective January 1, 2002)

**CHAPTER 7
WALL COVERING**

**SECTION R703
EXTERIOR COVERING**

*Revise Table 703.4 by adding the following:

Table 703.4 Weather- Resistant Siding Attachment and Minimum Thickness

SIDING MATERIAL	NOMINAL THICKNESS (inches)	JOINT TREATMENT	SHEATHING PAPER REQUIRED	NUMBER OR SPACING OF FASTENERS
Exterior Insulation and Finish Systems (footnote ¹)	3/4 Minimum, 4" maximum thickness of Insulation Board	(footnote ^s)	yes (footnote ^t)	Approved Corrosion Resistant Fastener or other approved attachment (footnote ^u)

Footnotes:

s. Sealant shall be applied in accordance with ASTM C 1193.

t. Weather resistant membrane shall be installed with provisions for drainage, without exception, over wood, wood structural panels, and sheathing of any type when installed on wood framing.

u. Insulation fastener type, number and spacing shall be as established by testing in accordance with ASTM E330 and accepted engineering practice, but insulation fastener spacing shall in all cases be a maximum of either: (1) 12 inches center to center vertically and 16 inches center to center horizontally or (2) 8 inches center to center vertically and 24 inches center to center horizontally.

(Effective January 1, 2002)

*Delete Section(s) R703.9, R703.9.1 and R703.9.2 and substitute the following:

703.9 Exterior Insulation and Finish System (EIFS)

703.9.1 Exterior Insulation and Finish Systems (EIFS) shall conform to Appendix L, Performance Requirements for Exterior Insulation and Finish Systems (EIFS).

703.9.2 Wall assemblies incorporating EIFS shall be provided with drainage as recognized in a current model building code Evaluation Report and shall conform to Appendix M, Requirements for Drainage Installed with Exterior Insulation and Finish Systems (EIFS).

703.9.3 Wall assemblies incorporating EIFS shall demonstrate drying potential as recognized in a current model building code Evaluation Report and shall be in conformance with Appendix N Requirements for Drying Potential for Exterior Insulation and Finish Systems (EIFS).

703.9.4 Installation of Exterior Insulation and Finish Systems (EIFS) Class PB shall comply with ASTM PS49, Standard Practice for Application of Class PB Exterior Insulation and Finish System. Where there is a conflict between ASTM PS49 and other provisions of the code, the other provisions shall apply instead of ASTM PS49.

703.9.5 Foam plastic insulation in Exterior Insulation and Finish Systems (EIFS) Class PB shall conform to the requirements of Chapter 3, Sections 318.1, 318.1.1, 318.1.2, 318.2.1, and 318.3.

703.9.6 Weather Resistive Barriers. The weather resistive barrier shall be asphalt saturated felt weighing at least 14 lbs. per hundred square feet (0.683 kg/m²), or conform to ASTM D226 Type I or equal, as determined by qualified testing. The barrier shall be free from holes and breaks and shall be applied over studs or sheathing of all exterior walls. Weather-resistant sheathing paper type barriers shall be applied horizontally with the upper layer lapped over the lower layer not less than 2 inches (52 mm). Where vertical joints occur, the felt or paper shall be lapped not less than 6 inches (152 mm). Approved surface applied type barriers shall be monolithic and continuous and shall be applied in accordance with the manufacturer's specifications and application instructions.

703.9.7 Flashing for Exterior Insulating and Finish Systems (EIFS). Flashing shall be approved, corrosion resistive, and provided in such a manner as to be leakproof and flashed to the exterior. Windows, doors, louvers and other similar openings shall be flashed. Windows shall be flashed at the top, sides and sills. Window heads shall be flashed to the exterior, except that self-flashing windows having a continuous lap of not less than 1 1/8 inches (28 mm) over sheathing material around the perimeter of the opening, including corners, do not require additional flashing at the head. Flashing shall be installed at the intersections of walls, including chimney chase walls, with roofs, decks, balconies, porches, stairs, landings and similar construction. The weather resistive barrier shall be continuous with the weather resistive barrier behind wall coverings adjacent to the EIFS or flashed to the exterior.

703.9.7.1 Refer to Appendix M for typical weather resistive barrier, flashing details, and installation details.

703.9.8 Sealants for Exterior Insulation and Finish Systems (EIFS). Sealants shall be installed between EIFS and adjoining construction or penetrations in accordance with ASTM C 1193. Minimum 3/4 inch (19 mm) wide sealant joints shall be installed at floor lines of wood framed floors. Minimum 1/2 inch (13 mm) wide sealant joints shall be installed at perimeters of wall openings such as for windows and doors. Sealants applied in a fillet configuration shall be installed over bond breaker tape or other pre-formed closed cell sealant backing. Sealants shall be installed so as not to block weeps or other water drainage. Sealants shall conform to ASTM C920, grade NS, Type M or S, Class 25. Sealants shall be tested in accordance with ASTM C 1135 and PS49. Minimum 50% elongation after conditioning shall be required.
(Effective January 1, 2002)

**CHAPTER 8
ROOF-CEILING CONSTRUCTION**

**SECTION R802
WOOD ROOF FRAMING**

*Revise Section R802.3 to read as follows:

R802.3 Framing details. Rafters shall be framed to the ridge board or to each other with a gusset plate as a tie. Where rafters meet to form a ridge they shall be placed directly opposite each other, or centerline offset not more than 1½ inches (38 mm). Ridge board shall be at least 1-inch (25.4 mm) nominal thickness and not less in depth than the cut end of the rafter. At all valleys and hips there shall be a valley or hip rafter not less than 2-inch (51 mm) nominal thickness and not less than the cut end of the rafter. Valley rafters shall be supported at the ridge...(remainder of section left unchanged).

(Effective January 1, 2002)

**SECTION R806
ROOF VENTILATION**

*Add new Section R806.4 to read as follows:

R806.4 Static Ventilating Devices. Manufactured static ventilating devices shall be identified by the manufacturer's mark, logo or product identification and the net free ventilating area (NFVA).

(Effective January 1, 2002)

**CHAPTER 9
ROOF ASSEMBLIES**

**SECTION R907
REROOFING**

*Revise Section R907.1 to read as follows:

R907.1 General. Materials and methods of application used for recovering or replacing an existing roof covering shall comply with the requirements of this chapter. Roof repairs to existing roofs and roof coverings shall comply with the provisions of Chapter 34 of the *International Building Code*.

(Effective January 1, 2002)

**CHAPTER 11
ENERGY EFFICIENCY**

*Delete Chapter 11 Energy Efficiency without substitution.

For energy code compliance refer to the Georgia State Energy Code for Buildings.
(Effective January 1, 2002)

**CHAPTER 12
MECHANICAL ADMINISTRATION**

**SECTION M1201
GENERAL**

*Delete Section M 1201.2 and substitute the following:

M1201.2 Alternate materials, design and methods of construction and equipment.

The provisions of this code are not intended to prevent the installation of any material or to prohibit any design or method of construction not specifically prescribed by this code, provided that any such alternative has been approved. An alternative material, design or method of construction shall be approved where the building official finds that the proposed design is satisfactory and complies with the intent of the provisions of this code, and that the material, method or work offered is, for the purpose intended, at least the equivalent of that prescribed in this code. Compliance with the specific performance-based provisions of the International Code Council (ICC) codes in lieu of specific requirements of this code shall also be permitted as an alternative.

M1201.2.1 Tests. Whenever there is insufficient evidence of compliance with the provisions of this code, or evidence that a material or method does not conform to the requirements of this code, or in order to substantiate claims for alternative materials and methods, the building official shall have the authority to require tests as evidence of compliance to be made at no expense to the jurisdiction. Test methods shall be as specified in this code or by other recognized test standards. In absence of recognized and accepted test methods, the building official shall approve the testing procedures. Tests shall be retained by the building official for the period required for the retention of public records.

(Effective January 1, 2002)

**CHAPTER 13
GENERAL MECHANICAL SYSTEM REQUIREMENTS**

**SECTION M1302
APPROVAL**

*Delete Section M 1302.1 and substitute the following:

M1302.1 General. See Section M 1201.2
(Effective January 1, 2002)

**SECTION M1305
APPLIANCE ACCESS**

*Revise Section M1305.1.3 first and last sentences to read as follows:

M1305.1.3 Appliances in attics. Attics containing appliances requiring access shall be provided with an opening and a clear and unobstructed passageway large enough to allow the removal of the largest appliance, but not less than 30 inches (762 mm) high and 22 inches (559 mm) wide to the appliance.

(Last sentence)

The clear access opening dimensions shall be a minimum of 20 inches by 30 inches (508 mm by 762 mm), where such dimensions are large enough to allow the removal of the largest appliance and be accessible by pull down stairs or other permanent steps.

(Effective January 1, 2002)

*Revise Section M1305.1.4.1 to read as follows:

M1305.1.4.1 Ground clearance. Equipment and appliances installed at grade level shall be supported on a level concrete slab or other approved material extending above grade a minimum of 2 inches (51 mm) or shall be suspended a minimum of 6 inches (152 mm) above adjoining grade.

(Effective January 1, 2002)

**CHAPTER 14
HEATING AND COOLING EQUIPMENT**

**SECTION M1401
GENERAL**

*Revise Section M1401.4 to read as follows:

M1401.4 Exterior installations. Equipment installed outdoors shall be listed and labeled for outdoor installation. Supports and foundations shall prevent excessive vibration, settlement or movement of the equipment. Equipment and appliances installed at grade level shall be supported on a level concrete slab or other approved material extending above grade a minimum of 2 inches (51 mm) or shall be suspended a minimum of 6 inches (152 mm) above adjoining grade.

(Effective January 1, 2002)

**CHAPTER 16
DUCT SYSTEMS**

**SECTION M1601
DUCT CONSTRUCTION**

* Revise Section M1601.2 by adding a last sentence to read as follows:

M1601.2 Factory-made ducts.

Each portion of a factory-made air duct system shall bear a label or mark indicating compliance with UL 181 and UL 181A and shall comply with the requirements of the Georgia State Energy Code for Buildings.

(Effective January 1, 2002)

*Revise Section M1601.2.1 by adding requirement #4 to read as follows:

M1601.2.1 Duct insulation materials.

4. All duct insulation materials shall comply with the requirements of the Georgia State Energy Code for Buildings.

(Effective January 1, 2002)

* Revise Section M1601.3.1 by adding a last sentence to read as follows:

M1601.3.1 Joints and seams. The joints and seams for the duct system shall also be sealed in accordance with the Georgia State Energy Code for Buildings.

(Effective January 1, 2002)

* Revise Section M1601.3.4 by adding requirement #4 to read as follows:

M1601.3.4 Duct insulation.

4. The Georgia State Energy Code for Buildings.

(Effective January 1, 2002)

**CHAPTER 20
BOILERS/WATER HEATERS**

**SECTION M2001
BOILERS**

*Revise Section M2001.1 by adding a last sentence to read as follows:

M2001.1 Installation.

The efficiencies of the boilers shall comply with the Georgia State Energy Code for Buildings.

(Effective January 1, 2002)

**CHAPTER 24
FUEL GAS**

**SECTION G2409 (308)
CLEARANCE REDUCTION**

*Add Exceptions to Section G2409.2 to read as follows:

G2409.2 Reduction table.

Exceptions: 1. Appliances that are approved and listed for such locations.
 2. Appliances installed in an enclosure communicating directly with a garage in which all combustion air is taken from the outdoors and the enclosure is equipped with a solid weather-stripped door and self-closing device.
(Effective January 1, 2002)

**SECTION G2414 (404)
PIPING SYSTEM INSTALLATION**

*Revise Section G2414.8 to read as follows:

G2414.8 Protection against corrosion. Metallic pipe or tubing exposed to corrosive action, such as soil condition or moisture, shall be protected in an approved manner. Ferrous metal exposed in exterior locations shall be protected from corrosion. Where dissimilar metals are joined underground, an insulating coupling or fitting shall be used. Piping shall not be laid in contact with cinders.
(Effective January 1, 2002)

**SECTION G2418 (408)
DRIPS AND SLOPED PIPING**

*Revise Section G2418.4 to read as follows:

G2418.4 Sediment trap. Where a sediment trap is not incorporated as part of the gas utilization equipment, a sediment trap shall be installed as close to the inlet of the equipment as practical. The sediment trap shall be either a tee fitting with a minimum 3 inch (76 mm) long capped nipple in the bottom outlet or other configuration approved as an effective sediment trap. Illuminating appliances, ranges, clothes dryers, decorative appliances for installation in vented fireplaces, decorative vented appliances, and outdoor grills need not be so equipped unless required by manufacturer's installation instructions.
(Effective January 1, 2002)

SECTION G2419 (409)
GAS SHUTOFF VALVES

*Revise Section G2419.1.2 by adding an exception to read as follows:

G2419.1.2 Prohibited locations. Shutoff valves shall be prohibited in concealed locations and spaces used as plenums.

Exception: Equipment shutoff valves required by the code shall be permitted to be installed in accessible above ceiling spaces containing vented gas utilization equipment.
(Effective January 1, 2002)

SECTION G2422 (413)
CNG GAS DISPENSING SYSTEMS

*Delete Section G2422.1 and substitute the following:

G2422.1 General. Under Georgia law, the Rules and Regulations of the Georgia Safety Fire Commissioner's Office govern the storage, delivery and dispensing of compressed natural gas. Refer to the Rules and Regulations of the Georgia Safety Fire Commissioner's Office and NFPA 52 for all requirements concerning compressed natural gas motor vehicle Fuel-dispensing stations.
(Effective January 1, 2002)

SECTION G2426 (503)
VENTING OF EQUIPMENT

*Revise Section G2426.10.2.2 by adding an exception to read as follows:

Section G2426.10.2.2 Vent connectors located in unconditioned areas.

Exception. Single-wall metal vent connectors shall be allowed in unconditioned areas other than attics and crawl spaces where the 97.5-percent value for outside design temperature is 10 degrees F (-18 degree C) or greater as shown in Figure R301.2 (1).
(Effective January 1, 2002)

SECTION G2443 (620)
UNVENTED ROOM HEATERS

*Revise Section G2443.1 to read as follows:

G2443.1 General. Unvented room heaters shall be tested in accordance with ANSI Z 21.11.2 and shall be installed in accordance with the conditions of the listing or the manufacturer's installation instructions. Unvented room heaters utilizing fuels other than gas shall be regulated by the Georgia State Minimum Standard Mechanical Code.
(Effective January 1, 2002)

**SECTION G2445 (622)
COOKING APPLIANCES**

*Delete Section **G2445.2 Prohibited location** without substitution.
(Effective January 1, 2002)

*Delete Section **G2445.3 Domestic appliances** without substitution.
(Effective January 1, 2002)

APPENDIX L

*Add Appendix L to read as follows:

**PERFORMANCE REQUIREMENTS FOR EXTERIOR INSULATIONS AND FINISH
SYSTEMS (EIFS)**

The system and its components shall meet or exceed the following performance standards:

System Performance

Characteristic	Test Method	Acceptance Criteria
L 1. 1 Abrasion Resistance	ASTM D 968	No cracking, checking or loss of film integrity at 528-quarts (500 liters) of sand
L 1.2 Accelerated Weathering	ASTM G 23	No deleterious effects ¹ after 2000 hours viewed under 5X magnification
L 1. 3 Freeze/Thaw Resistance	Air dry at 120 (49 ⁰ C) degrees Fahrenheit. Minimum eight hours total immersion in water at 70 degrees (21 ⁰ C) Fahrenheit to 80 degrees (27 ⁰ C) Fahrenheit for eight hours then exposure to 20 degrees (7 ⁰ C) Fahrenheit for 16 hours.	10 cycles. No deleterious effects ¹ viewed under 5X magnification
L 1.4 Mildew Resistance	ASTM D3273	No growth supported during 28-day exposure time.
L 1.5 Salt Spray Resistance	ASTM B117	No deleterious effects ¹ at 300 hour exposure.

L 1.6 Tensile Adhesion	ASTM C297	No failure in the adhesive, base coat or finish coat. Minimum 5 PSI(34.5 kPa) tensile strength before and after freeze/thaw and accelerated weathering test.
L 1.7 Water Penetration	ASTM E331	No water penetration beyond the plane of the base coat/ insulation board interface after 15 minutes at 6.24 psf (299 Pa), or 20% of positive design wind pressure, which ever is greater.
L 1.8 WaterResistance	ASTM D2247	No deleterious effects ¹ at 14 day exposure.
L 1.9 Wind Load	ASTM E330	Withstand negative and positive wind loads required by building code.

L 2 - 0 Component Performance:

L 2.1 Physical Properties and Requirements for EPS	ASTM C578	Meets TYPE I
L 2.2 Physical Properties and Requirements for Polyisocyanurate Thermal Insulation Board	ASTM C 1289	Meets TYPE II
L 2.3 Physical Properties	ASTM D 5035	Requirements for textile fabrics (strip force).

NOTE 1: No deleterious effects: no cracking, checking, crazing, erosion, rusting, blistering, peeling or delamination.

(Effective January 1, 2002)

APPENDIX M

* Add Appendix M to read as follows:

REQUIREMENTS FOR DRAINAGE INSTALLED WITH EXTERIOR INSULATION AND FINISH SYSTEMS (EIFS)

M1.01 Scope:

These requirements cover the drainage of water from wall construction incorporating EIFS and weather resistive barriers. Drainage is provided to prevent water intrusion beyond the water resistive barrier and to discharge water to the exterior.

M2.01 Reference Documents

ASTM Standards E 331 Test Method for Water Penetration of Exterior Windows, Curtain Walls, and Doors by Uniform Static Air Pressure Difference.

M3.01 Terminology

Descriptions of Terms Specific to this Standard:

M3.01.1 Drainage: The collection and discharge of water gravity flow.

M4.01 Drainage of Water

M4.01.1 Walls incorporating EIFS and drainage shall be constructed to collect incidental water at the exterior outside faces of a weather resistive barrier and flashing. The wall assembly shall allow water collected at the outside faces of the weather resistive barrier and flashing to flow by gravity to the exterior.

M4.01.2 The weather resistive barrier shall be integrated with the flashing to prevent water intrusion to the interior.

M4.01.3 Drainage shall be confirmed by testing in accordance with ASTM E331 and 5.01.

M5.01 Test Method For Determining The Drainage Performance of Wall Assemblies Clad With Exterior Insulation and Finish Systems (EIFS).

This test method consists of testing EIFS clad wall assemblies for Drainage Performance by ASTM E331, Standard Test Method for Water Penetration of Exterior Windows, Curtain Walls and Doors by Uniform Static Air Pressure Difference, except as described otherwise herein.

- M5.01.1 **Scope:**
This test method evaluates the drainage performance of EIFS when subjected to water applied in conjunction with a positive uniform static air pressure.
- M5.01.2 **Test Method**
ASTM E331
- M5.01.3 **Apparatus**
ASTM E 331 for application of water and positive uniform static air pressure and a catchment to collect and measure drained water.
- M5.01.4 **Test Specimen**
- M5.01.4.1 The EIFS clad wall test specimens shall be a minimum of 4'x 8' (123 cm x 246 cm).
- M5.01.4.2 Minimum of four test specimens plus a control shall be assembled and allowed to cure for 28 days prior to test. The test specimens shall contain a fault. Dimensions and location of the fault are shown in Figure M-1.0.
- M5.01.4.3 The EIFS assemblies shall be installed with the materials, details, and methods of assembly as required by the manufacturer.
- M5.01.4.3.1 For acceptance of wall assemblies with wood-based sheathing, the test wall shall include the sheathing to be accepted.
- M5.01.4.4 The supporting framework for the EIFS wall assemblies shall be of wood or metal stud construction with framing spacing as required by the manufacturer. The standard framing spacing is 16" (41 cm) on center.
- M5.01.4.5 The test specimens shall be constructed to allow observation of drainage.
- M5.01.5 **Test Procedure:**
- M5.01.5.1 Test pressure difference shall be minimum 6.24 pounds per square foot (psf).
- M5.01.5.2 Water delivery to the exterior surface shall be uniform and at a rate of 5.0 gallons per square foot hour. (19 liters per 0.093 square meter hour)
- M5.01.5.3 Water and pressure duration shall be minimum 15 minutes.
- M5.01.5.4 Subject the four test specimens to the conditions in 5. 1 and 5.3. Observe and verify that specimens drain freely.
- M5.01.5.5 Allow each specimen to drain in the vertical position.

M5.01.5.6 After one hour of drainage, select one of the test specimens; disassemble and verify drainage by observation. **Note:** Disassembly of wall must assure inspection of all wall components. Any water accumulation beyond incidental beading due to surface tension shall be reported.

M6.01 **REPORT**

M6.01.1 Follow ASTM E331 Sections 12.1.1, 12.1.2, 12.1.7, 12.1.9, 12.1.10, and 12.2 plus the following:

M6.01.2 Observations from 5.4, 5.5, and 5.7.

M6.01.3 Details of assembly, including a description of components, mixing and application, thickness of components and a statement of conformance to the manufacturer's application instructions.

M6.01.4 Photographic video documentation of test specimens, including assembly, components, drainage verification, and samples removed in 5.8.

M6.01 .5 Detailed drawings of the test specimens.

M6.01.6 A record of all points of water penetration to the cavity and **drainage** performance. (Effective January 1, 2002)

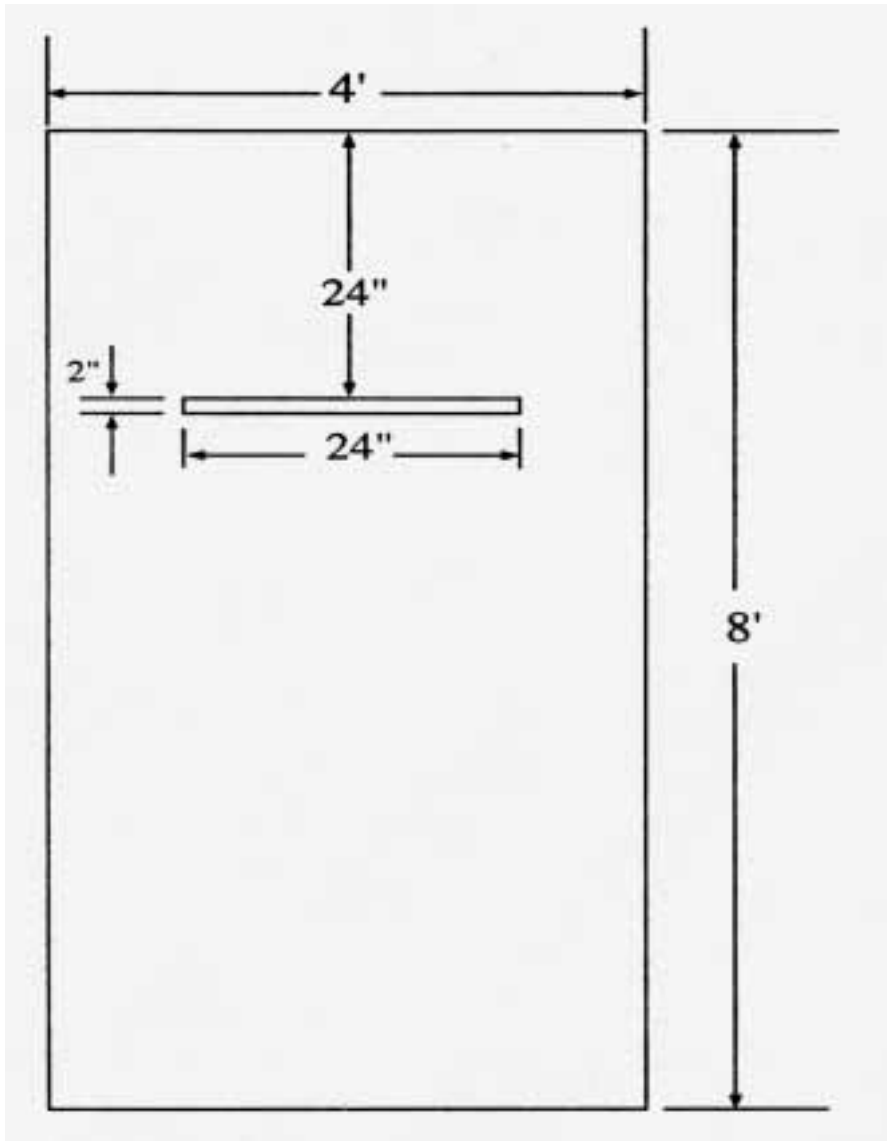

Figure M-1.0

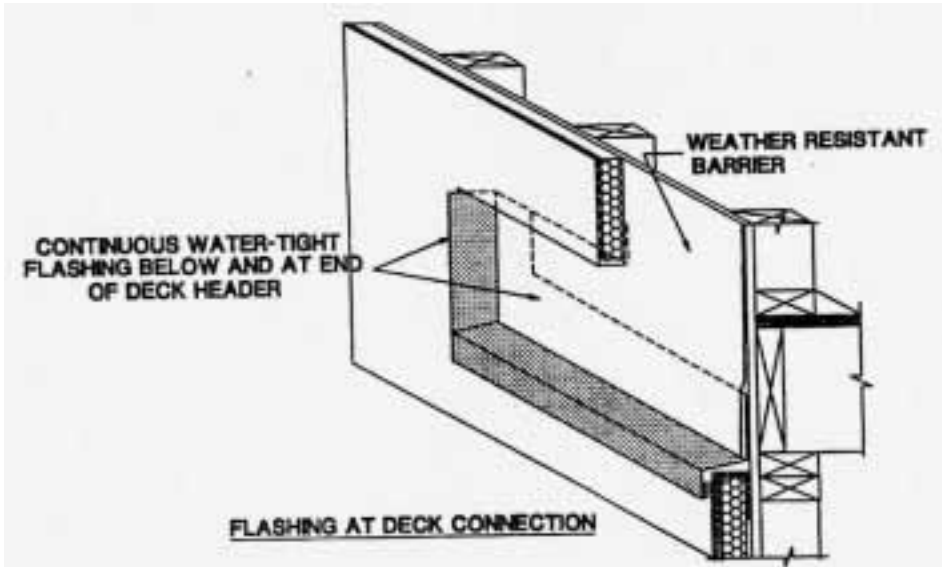

Figure M-2.0

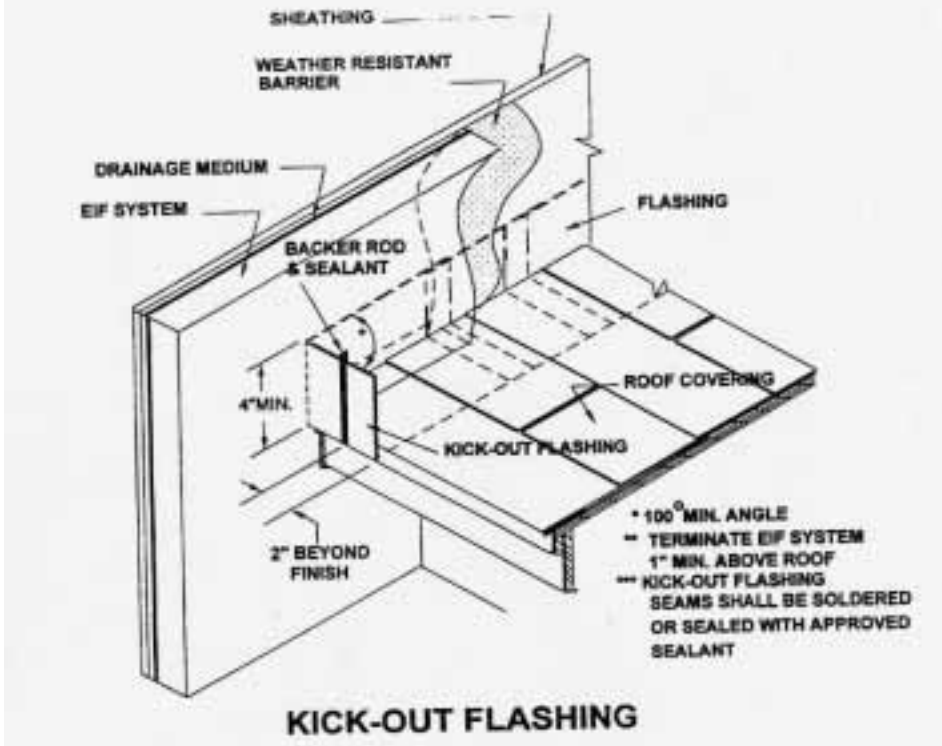

Figure M-2.1

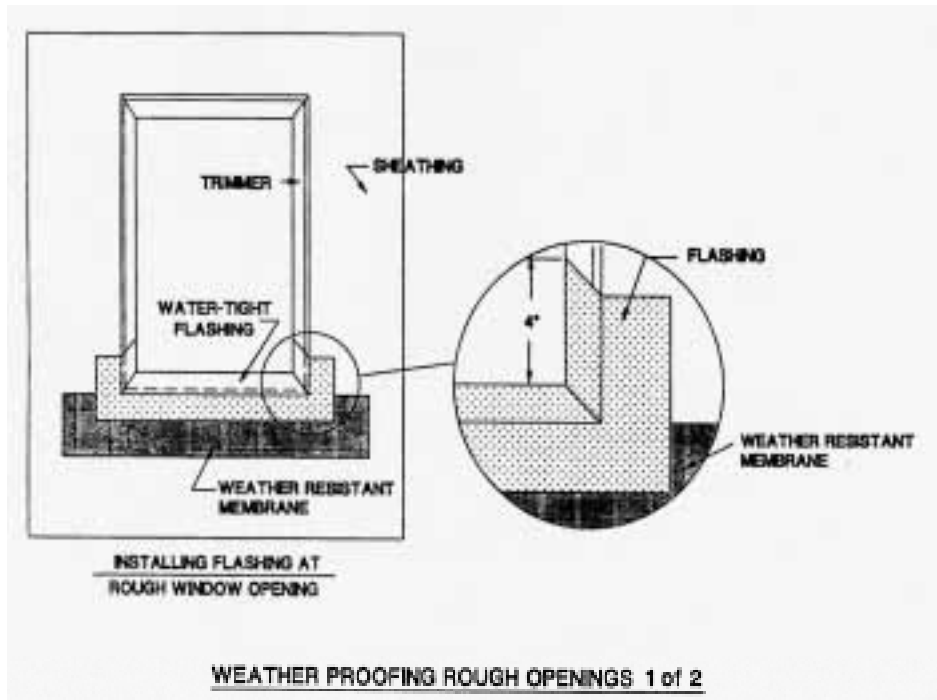

Figure M-2.2(a)

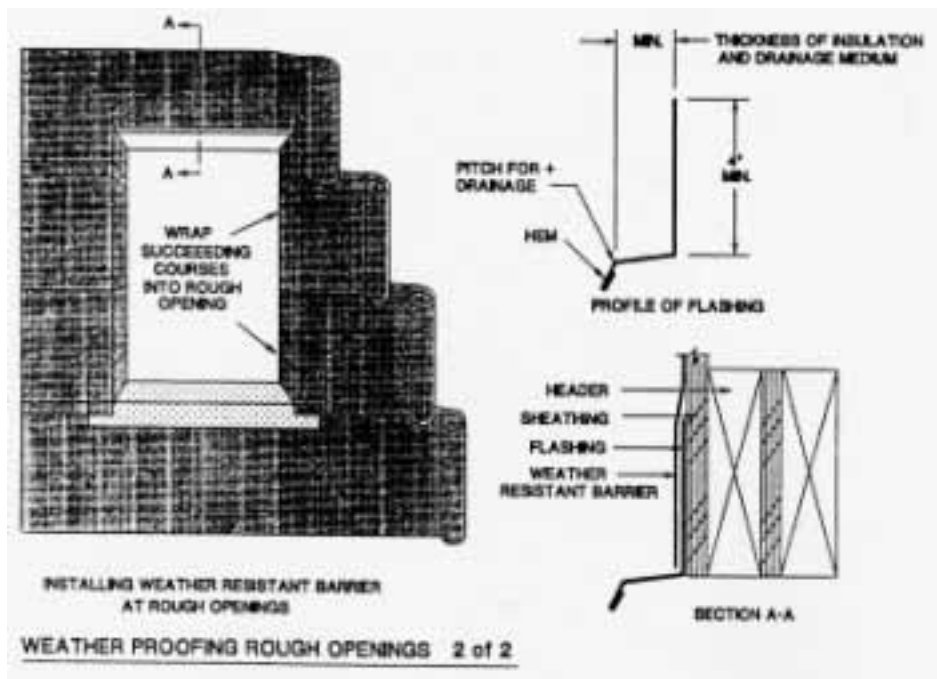

Figure M-2.2(b)

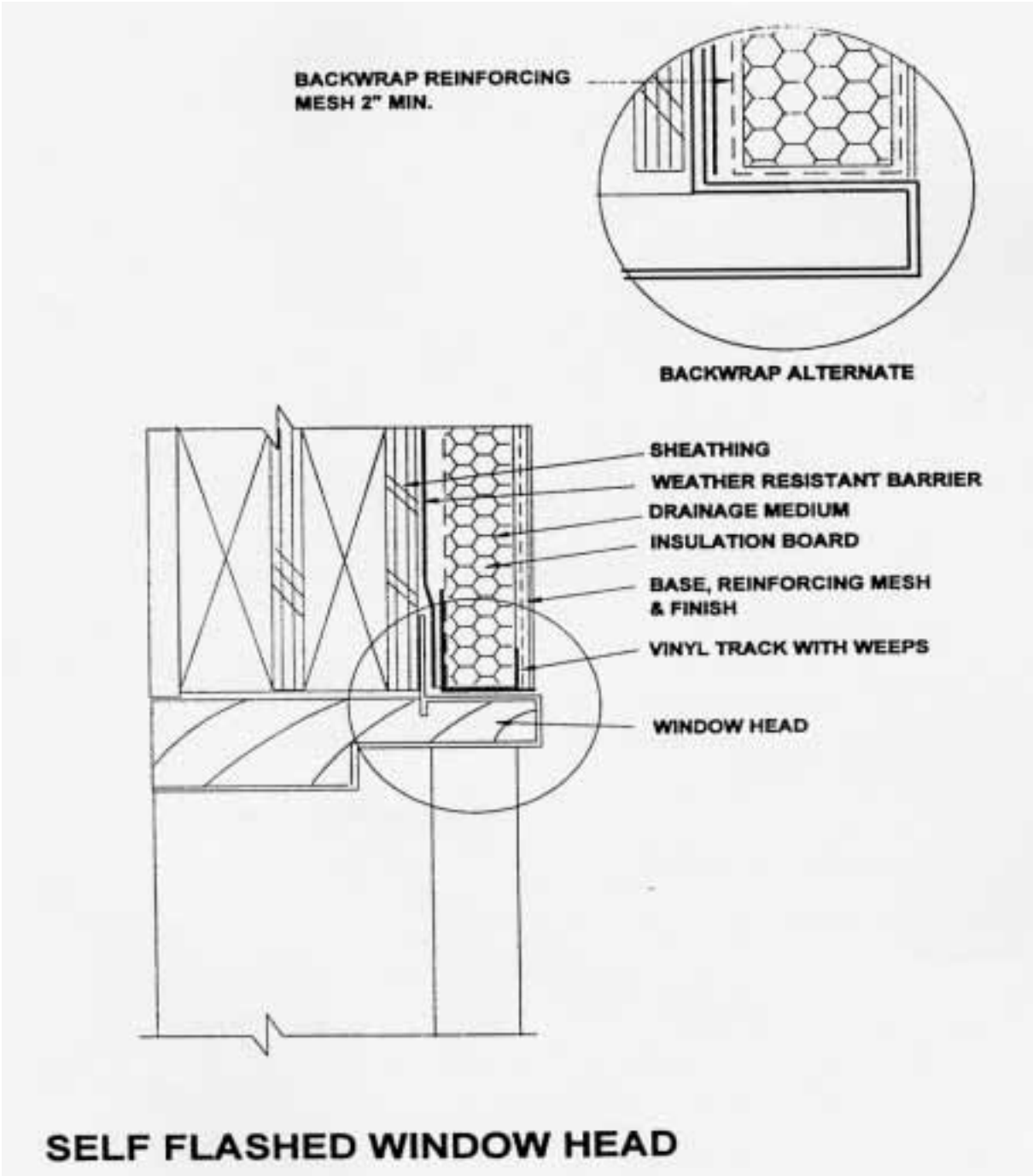

Figure M-2.3

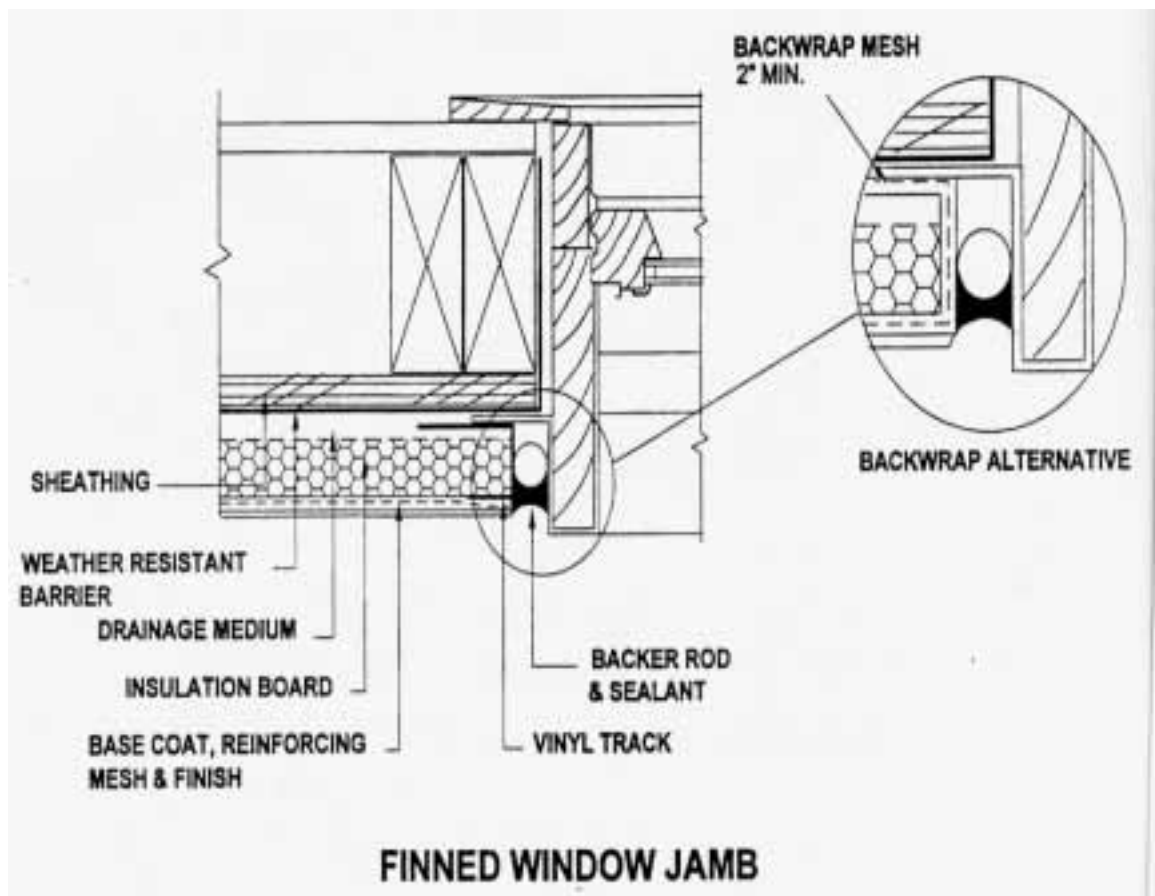

Figure M-2.4

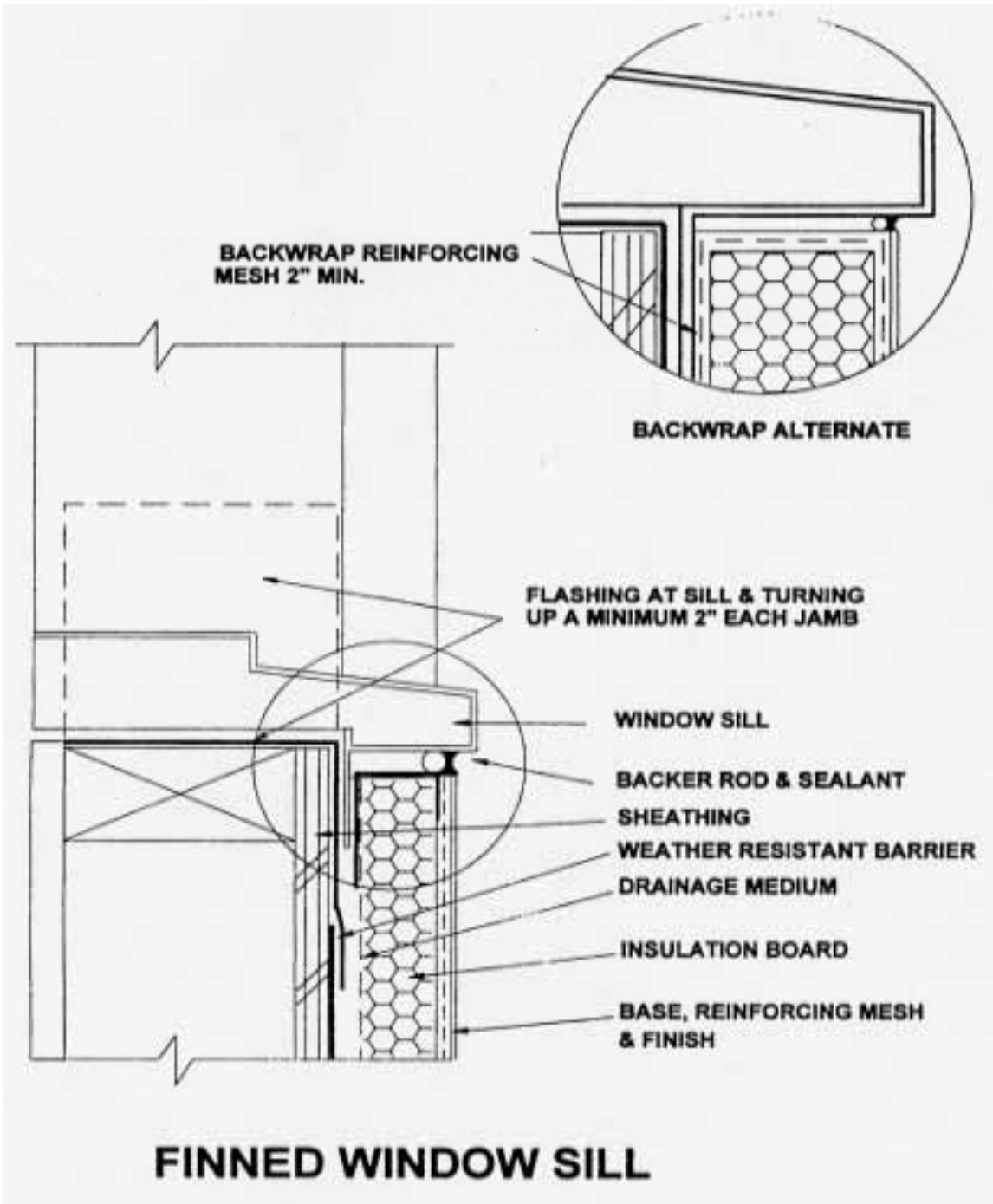

Figure M-2.5

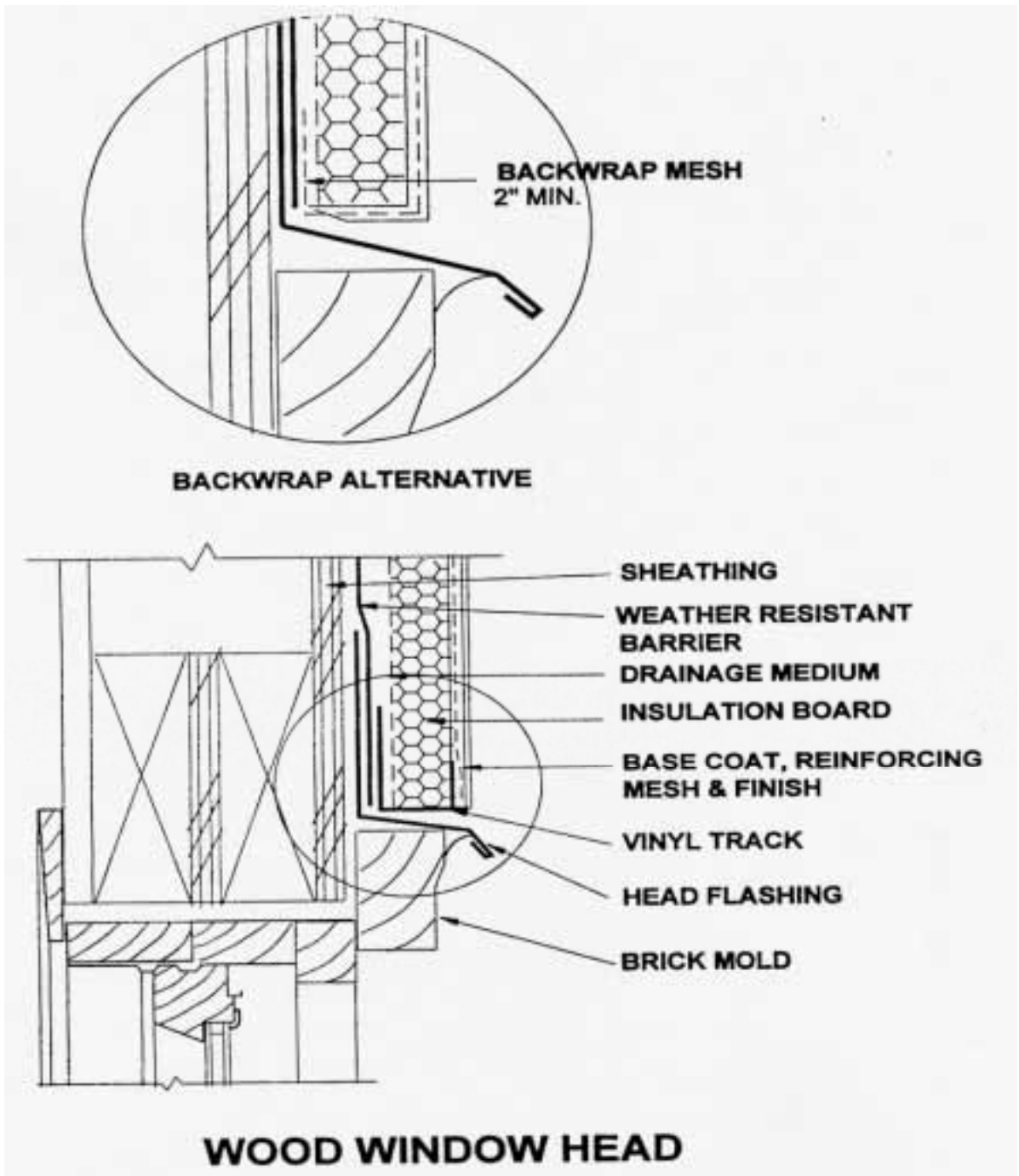

Figure M-2.6

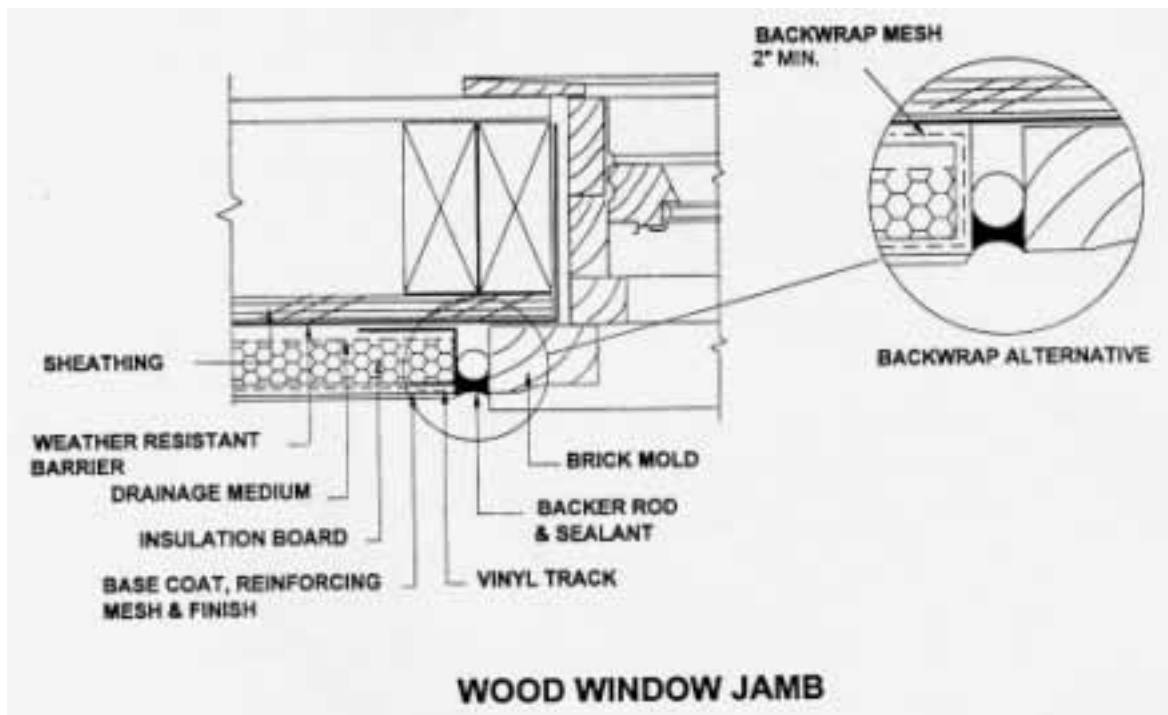

Figure M-2.7

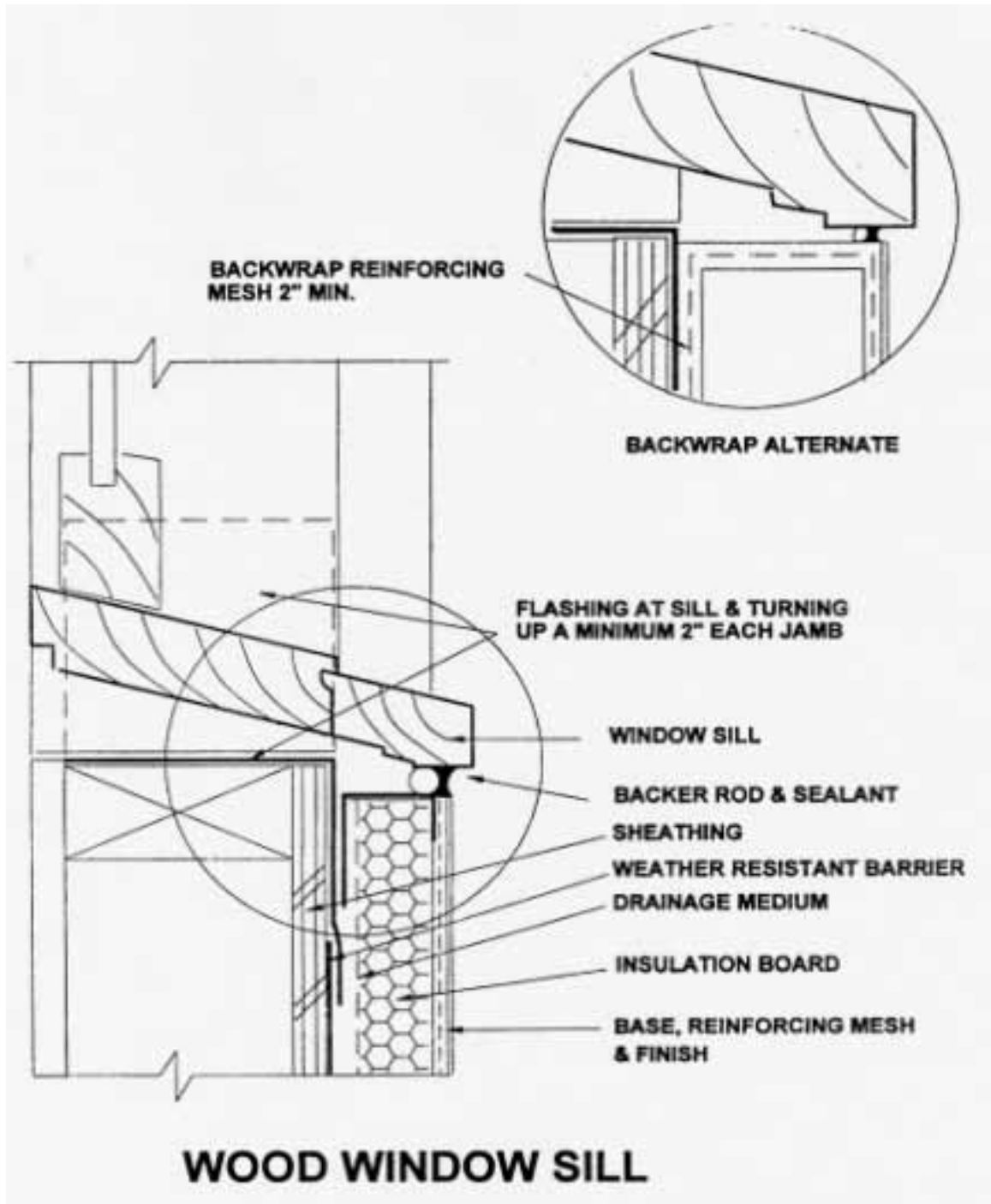

Figure M-2.8

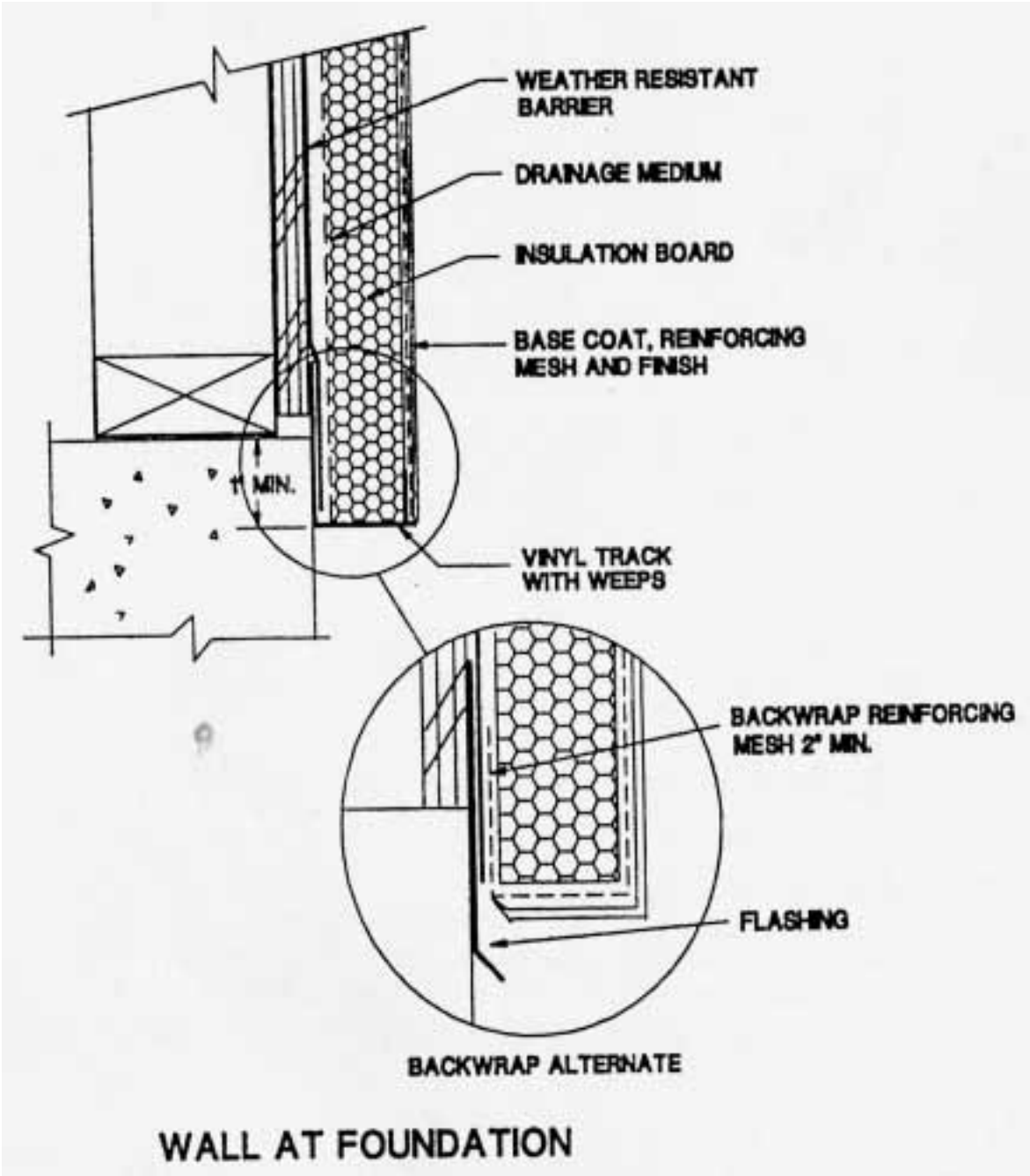

Figure M-2.9

APPENDIX N

*Add new Appendix N to read as follows:

REQUIREMENTS FOR DRYING POTENTIAL FOR EXTERIOR INSULATION AND FINISH SYSTEMS (EIFS)

N1.01 SCOPE

These requirements cover the potential for drying of wall construction incorporating EIFS and drainage. Drying of water in excess of 1 ounce per square foot shall be confirmed by testing in accordance with ASTM E331 and Section 2.01.

N2.01 TEST METHOD

N2.01.1 Follow Appendix M, Requirements for Drainage Installed with Exterior Insulation Finish Systems (EIFS), Sections 5.01 through 5.01.5.6.

N2.01.2 Allow three test specimens plus the control specimen to dry in a conditioned space (73 degrees Fahrenheit \pm 4 degrees @ 50% Relative Humidity) (23 degrees Centigrade \pm 2 degrees @ 50% Relative Humidity) for 72 hours. {NOTE: These are usually the same test specimens tested for drainage}.

N2.01.3 After 72 hours of drying, cut three 12" x 12" (369 cm x 369 cm) samples to include all components of the assembly except framing from each test specimen and the control, as shown in figure N-1.0.

N2.01.4 Record observations.

N2.01.5 Immediately weigh each sample and place in an oven controlled at 120 \pm 10 degrees Fahrenheit (49 degrees Centigrade \pm 5 degrees) until constant weight is obtained. Record weight loss of each sample to the nearest .01 ounce (31 grams).

N2.01.6 Determine the average weight loss for the nine samples (TSRM) from the test specimens. Determine the average weight loss for the three control samples (CSBM).

N 3.0 1TSRM - CSBM = SRM

TSRM - Average residual moisture in nine test samples (oz.) (gr.)

CSRM - Average background moisture in three control samples (oz.) (gr.)

SRM - Average residual moisture in system per square foot; (ounce per square foot)
(gr. per square meter).

N4.0 1 REPORT

A record of all weights as recorded in Section 2.01.5 and 2.01.6 to evaluate drying potential.

N5.01 ACCEPTANCE

SRM (Average Residual Moisture in system per square foot) shall not exceed 1 ounce per square foot.

(Effective January 1, 2002)

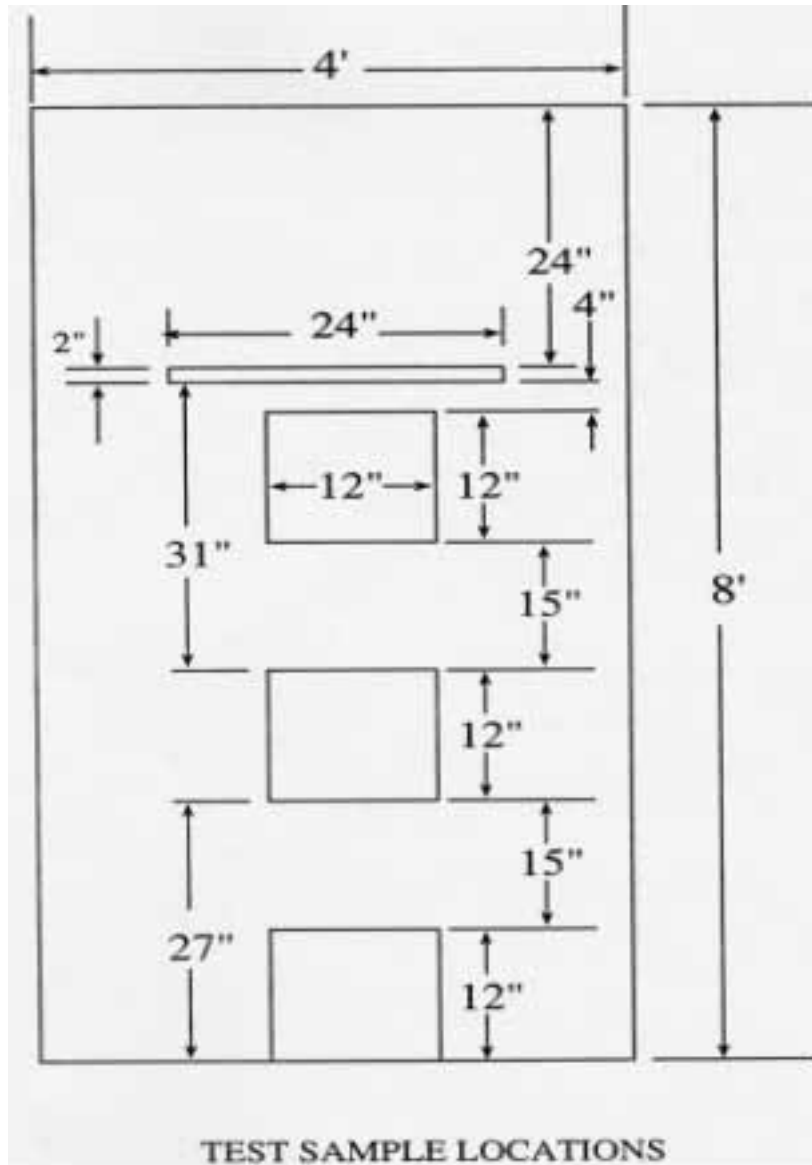

Figure N-1.0

End of Amendments.



Georgia State Amendments to the CABO One and Two Family Dwelling Code

(2000 Edition)



**Georgia Department of Community Affairs
Office of Coordinated Planning
60 Executive Park South, N.E.
Atlanta, Georgia 30329-2231
(404) 679-3118
www.dca.state.ga.us**

Revised January 1, 2003

ONE AND TWO FAMILY DWELLING CODE
(International Residential Code for
One and Two Family Dwellings)

The CABO ONE AND TWO FAMILY DWELLING CODE (International Residential Code for One and Two Family Dwellings), 2000 Edition, published by the Southern Building Code Congress International, Inc., when used in conjunction with these Georgia Amendments, shall constitute the official *Georgia State Minimum Standard One and Two Family Dwelling Code*.

THESE AMENDMENTS ARE TO BE USED IN ADDITION TO THOSE AMENDMENTS ADOPTED EFFECTIVE JANUARY 1, 2002. WHEN USED TOGETHER THEY CONSTITUTE THE OFFICIAL GEORGIA STATE MINIMUM STANDARD ONE AND TWO FAMILY DWELLING CODE.

Plumbing (Chapters 25 through 32) are deleted from the *CABO One and Two Family Dwelling Code* according to Title 8, Chapter 2, Article 1, Part 2 of the Official Code of Georgia Annotated.

Electrical (Chapters 33 through 42) are deleted and substitute for Electrical requirements the *Georgia State Minimum Standard Electrical Code (National Electrical Code)*.

Appendices

Appendices are not enforceable unless they are specifically referenced in the body of the code or adopted for enforcement in the ordinance of the authority having jurisdiction.

GEORGIA STATE AMENDMENTS

CODE REFERENCE:

- (a) Change all references from the ICC Electrical Code to the Georgia State Minimum Standard National Electrical Code.
- (b) Change all references from the International Energy Conservation Code to the Georgia State Energy Code for Buildings. The Georgia State Energy Code for Buildings shall be used for heating and air conditioning equipment.

Scope

The provisions of the CABO One and Two Family Dwelling Code (International Residential Code for One and Two Family Dwellings) shall apply to the construction, alteration, movement, enlargement, replacement, repair, equipment, use and occupancy, location, removal and demolition of detached one and two family dwellings and multiple single family dwellings (townhouses) not more than three stories in height with a separate means of egress and their accessory structures.

**GEORGIA STATE MINIMUM
REQUIREMENTS FOR BOILER/WATER HEATERS AND PRESSURE VESSELS**

(a) The State's Minimum requirements for Boiler/Water Heaters and Pressure Vessels, over 200,000 BTU (58.56 kW), 210 degrees Fahrenheit, or 120 gallons capacity, shall be established by O.C.G.A. Title 34, Chapter 11, and the Rules and Regulations of the Georgia Department of Labor (Effective January 1, 2002).

**Revise the CABO One and Two Family Dwelling Code (International Residential Code for One and Two Family Dwellings), 2000 Edition, as follows:*

**CHAPTER 2
DEFINITIONS**

*Revise Section R202 by adding the following definition:

VALVE

Point of Delivery Service Shutoff. The point of delivery for natural gas systems is the outlet of the service meter assembly or the outlet of the service regulator or service shutoff valve where a meter is not provided. Where a valve is provided at the outlet of the service meter assembly, such valve shall be considered to be downstream of the point of delivery. The point of delivery for undiluted liquefied petroleum gas systems is the outlet of the first stage pressure regulator that provides utilization pressure, exclusive of line gas regulators, in the system.
(Effective January 1, 2003)

**SECTION R703
EXTERIOR COVERING**

*Add the following exceptions to Section R703.7:

R703.7 Stone and masonry veneer, general. All stone and masonry veneer shall be installed in accordance with this chapter, Table R703.4 and Figure R703.7. Such veneers installed over a backing of wood or cold-formed steel shall be limited to the first story above grade and shall not exceed 5 inches (127 mm) in thickness.

Exceptions:

3. For detached one or two family dwellings with a maximum nominal thickness of 4 inches (102 mm) of exterior masonry veneer with a backing of wood frame located in Seismic Design Category D₁, the masonry veneer shall not exceed 20 feet (6096 mm) in height above a noncombustible foundation, with an additional 8 feet (2438 mm) permitted for gabled ends, or 30 feet (9144 mm) in height with an additional 8 feet (2438 mm) permitted for gabled ends where the lower 10 feet (3048 mm) has a backing of concrete or masonry wall provided the following criteria are met:

- 3.1. Braced wall panels shall be constructed with a minimum of 7/16 inch (11.1 mm) thick sheathing fastened with 8d common nails at 4 inches (102 mm) on center on panel edges and at 12 inches (305 mm) on center on intermediate supports.
 - 3.2. The bracing of the top story shall be located at each end and at least every 25 feet (7620 mm) on center but not less than 45% of the braced wall line. The bracing of the first story shall be as provided in Table R602.10.3.
 - 3.3. Hold down connectors shall be provided at the ends of braced walls for the second floor to first floor wall assembly with an allowable design of 2100 lbs. (952.5 kg). Hold down connectors shall be provided at the ends of each wall segment of the braced walls for the first floor to foundation assembly with an allowable design of 3700 lbs. (1678 kg). In all cases, the hold down connector force shall be transferred to the foundation.
 - 3.4. Cripple walls shall not be permitted.
4. For detached one and two-family dwellings with a maximum actual thickness of 3 inches (76 mm) of exterior masonry veneer with a backing of wood frame located in Seismic Design Category D₂, the masonry veneer shall not exceed 20 feet (6096 mm) in height above a noncombustible foundation, with an additional 8 feet (2438 mm) permitted for gabled ends, or 30 feet (9144 mm) in height with an additional 8 feet (2438 mm) permitted for gabled ends where the lower 10 feet (3048 mm) has a backing of concrete or masonry wall, provided the following criteria are met:
 - 4.1. Braced wall panels shall be constructed with a minimum of 7/16 inch (11.1 mm) thick sheathing fastened with 8d common nails at 4 inches (102 mm) on center on panel edges and at 12 inches (305 mm) on center on intermediate supports.
 - 4.2. The bracing of the top story shall be located at each end and at least every 25 feet (7620 mm) on center but not less than 55% of the braced wall line. The bracing of the first story shall be as provided in Table R602.10.3.
 - 4.3. Hold down connectors shall be provided at the ends of braced walls for the second floor to first floor wall assembly with an allowable design of 2300 lbs. (1043 kg). Hold down connectors shall be provided at the ends of each wall segment of the braced walls for the first floor to foundation assembly with an allowable design of 3900 lbs. (1769 kg). In all cases, the hold down connector force shall be transferred to the foundation.
 - 4.4. Cripple walls shall not be permitted.

(Effective January 1, 2003)

*Revise Section R703.7.4.1.2 to read as follows:

R703.7.4.1.2 Seismic Design Categories D₁ and D₂. In Seismic Design Categories D₁ and D₂, provide single-wire joint reinforcement, a minimum of No. 9 gage, at a spacing of 18 inches (457 mm) on center vertically. The joint reinforcement shall be continuous in the veneer bed joint, with lap splices permitted between the veneer ties.

(Effective January 1, 2003)

**CHAPTER 24
FUEL GAS**

**SECTION G2419 (409)
GAS SHUTOFF VALVES**

*Add new Section G2419.2.1 to read as follows:

G2419.2.1 Point of Delivery Service Valve. Where the point of delivery is the outlet of the service meter assembly, or the outlet of the service regulator a service shutoff valve shall be installed. Such valve is considered to be part of the customer piping system.
(Effective January 1, 2003)

End of Amendments.



Georgia State Amendments to the CABO One and Two Family Dwelling Code

(2000 Edition)



Georgia Department of Community Affairs
Office of Coordinated Planning
60 Executive Park South, N.E.
Atlanta, Georgia 30329-2231
(404) 679-3118
www.dca.state.ga.us

Revised January 1, 2004

ONE AND TWO FAMILY DWELLING CODE
(International Residential Code for
One and Two Family Dwellings)

The CABO ONE AND TWO FAMILY DWELLING CODE (International Residential Code for One and Two Family Dwellings), 2000 Edition, published by the Southern Building Code Congress International, Inc., when used in conjunction with these Georgia Amendments, shall constitute the official *Georgia State Minimum Standard One and Two Family Dwelling Code*.

THESE AMENDMENTS ARE TO BE USED IN ADDITION TO THOSE AMENDMENTS ADOPTED EFFECTIVE JANUARY 1, 2002 AND JANUARY 1, 2003. WHEN USED TOGETHER THEY CONSTITUTE THE OFFICIAL GEORGIA STATE MINIMUM STANDARD ONE AND TWO FAMILY DWELLING CODE.

Plumbing (Chapters 25 through 32) are deleted from the *CABO One and Two Family Dwelling Code* according to Title 8, Chapter 2, Article 1, Part 2 of the Official Code of Georgia Annotated.

Electrical (Chapters 33 through 42) are deleted and substitute for Electrical requirements the *Georgia State Minimum Standard Electrical Code (National Electrical Code)*.

Appendices

Appendices are not enforceable unless they are specifically referenced in the body of the code or adopted for enforcement in the ordinance of the authority having jurisdiction.

GEORGIA STATE AMENDMENTS

CODE REFERENCE:

- (a) Change all references from the ICC Electrical Code to the Georgia State Minimum Standard Electrical Code.
- (b) Change all references from the International Energy Conservation Code to the Georgia State Energy Code for Buildings. The Georgia State Energy Code for Buildings shall be used for heating and air conditioning equipment.

Scope

The provisions of the CABO One and Two Family Dwelling Code (International Residential Code for One and Two Family Dwellings) shall apply to the construction, alteration, movement, enlargement, replacement, repair, equipment, use and occupancy, location, removal and demolition of detached one and two family dwellings and multiple single family dwellings (townhouses) not more than three stories in height with a separate means of egress and their accessory structures.

**GEORGIA STATE MINIMUM
REQUIREMENTS FOR BOILER/WATER HEATERS AND PRESSURE VESSELS**

(a) The State's Minimum requirements for Boilers/Water Heaters and Pressure Vessels over 200,000 BTU (58.56 kW), 210 degrees Fahrenheit, or 120 gallons capacity, shall be established by O.C.G.A. Title 34, Chapter 11, and the Rules and Regulations of the Georgia Department of Labor. (Effective January 1, 2004)

*Revise the CABO One and Two Family Dwelling Code (International Residential Code for One and Two Family Dwellings), 2000 Edition, as follows:

**CHAPTER 3
BUILDING PLANNING**

**SECTION R307
TOILET, BATH AND SHOWER SPACES**

*Revise Section R307.1 to read as follows:

R307.1 Space required. Fixtures shall be spaced as per Figure R307.2. Doors are permitted to encroach on clearance areas.
(Effective January 1, 2004)

**SECTION R309
GARAGES AND CARPORTS**

*Revise Section R309.1.1 to read as follows:

R309.1.1 Duct penetration. Ducts in the garage and ducts penetrating the walls or ceilings separating the dwelling from the garage shall be constructed of a minimum No. 26 gauge (0.48 mm) sheet steel or other approved Class 0 or Class 1 air duct material, except fibrous glass flex duct, and shall have no openings into the garage unless the garage space is conditioned by a separate unit. Fibrous glass flexible air ducts and air duct connectors are not permitted to pass through the wall or ceiling assembly. (Effective January 1, 2004)

**SECTION R310
EMERGENCY ESCAPE AND RESCUE OPENINGS**

*Revise Section R310.1.2 to read as follows:

R310.1.2 Minimum opening height. The minimum net clear opening height shall be 24 inches (610 mm). Projections not exceeding 1” total, such as, window slides or guides, driplips and weatherstripping are permitted in the clear opening.
(Effective January 1, 2004)

*Revise Section R310.1.3 to read as follows:

R310.1.3 Minimum opening width. The minimum net clear opening width shall be 20 inches (508 mm). Projections not exceeding 1” total, such as, window slides or guides, driplips and weatherstripping are permitted in the clear opening. (Effective January 1, 2004)

**SECTION R322
MOISTURE VAPOR RETARDERS**

*Delete Section R322.1 of the existing Georgia Amendments Revised January 1, 2002 entirely and substitute to read as follows:

R322.1 Moisture Control. The requirements for Moisture Vapor Retarders shall be governed by the Georgia Energy Code for Buildings (International Energy Conservation Code) Section 502.1.1. (Effective January 1, 2004)

**SECTION R324
PROTECTION AGAINST TERMITES**

*Delete Section R324.1 of the existing Georgia Amendments Revised January 1, 2002 and substitute the following to read:

*Revise Section R324.1 by adding a sentence at the end of section to read as follows:

R324.1 Subterranean termite control. ...any combination of these methods or any other method which has been approved for use by the State Department of Agriculture.
(Effective January 1, 2004)

*Add New Subsection R324.1.1 to read as follows:

R324.1.1 Inspection of separation areas outside structure. The minimum clearance between exterior cladding and grade shall be 6” to soil and 2” to impervious surfaces such as concrete or asphalt.

Exception: Walls covered by masonry veneer.
(Effective January 1, 2004)

**CHAPTER 4
FOUNDATIONS**

**SECTION 403
FOOTINGS**

*Revise Section R403.1.4 to read as follows:

R403.1.4 Minimum depth. All exterior footings and foundation systems shall extend below the frost line specified in Table R301.2(1). All exterior footings shall be placed at least 12 inches below grade. (Effective January 1, 2004)

**SECTION R404
FOUNDATION WALLS**

*Revise Section R404.1.7, Exception 2 of the existing Georgia Amendments Revised January 1, 2002 to read as follows:

R404.1.7 Backfill placement.

Exception:

2) Such bracing is not required for poured concrete walls which have cured at least 7 (seven) days or are of sufficient strength as determined by an engineer.
(Effective January 1, 2004)

**CHAPTER 13
GENERAL MECHANICAL SYSTEM REQUIREMENTS**

**SECTION M1305
APPLIANCE ACCESS**

*Revise first sentence of Section M1305.1.4 to read as follows:

M1305.1.4 Appliances under floors. Underfloor spaces containing appliances requiring access shall be provided with an unobstructed passageway large enough to remove the largest appliance, but not less than 30 inches (762 mm) high and 22 inches (559 mm) wide.
(Effective January 1, 2004)

CHAPTER 43
REFERENCED STANDARDS

*Revise the AF&PA Standard reference number for WFCM to read as follows:

AF&PA American Forest and Paper Association
111 19th Street, NW, #800
Washington DC 20036

Standard reference number	Title	Referenced in code section number
WFCM	ANSI/AF&PA Wood Frame Construction Manual for One and Two Family Dwellings, 2001 Edition (Effective January 1, 2004)	R301.2.1.1

End of Amendments.